

### Right Angle Grinders for use with Depressed Center & Type 1 Grinding/Cut-off Wheels 7" (18 mm) – 10" (250 mm) 2 H.P. (1500 w)

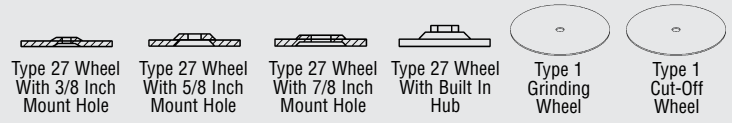

**Air Inlet Size: 1/2" NPT**  
**Hose Size Recommendations: 1/2" (13 mm)**

**Extra Charge Accessories**  
 • Depressed Center Wheel Kit • Sanding Pads

**Standard Equipment**  
 • Tool • Operating Instructions and Service Manual

**Special Features**  
 • Spindle Lock Mechanism (Standard Equipment)  
 • 2.0 H.P. Motor • Dual Position Dead Handle  
 • Adjustable Guard Position

The depressed center wheel adapters are not supplied as standard equipment with the tools. If you are using a wheel that requires the adapters, they must be purchased separately.

RIGHT ANGLE GRINDERS

### Quick Order Number

Model Number	Guard Size	Maximum Operating Speed	Throttle Handle Type	
			Standard	Safety
520RA	7 Inch	8000 RPM	520RAXL;727	520RAXK;727
	9 Inch	6000 RPM	520RAXL;927	520RAXK;927
	10 Inch	6000 RPM	520RA2XL;1041	520RA2XK;1041

This chart has been provided as a means to quickly identify a particular tool. The ordering numbers listed represent the most common versions of our tools. If more specialized versions are required, please build your model number per the following model number flow chart.

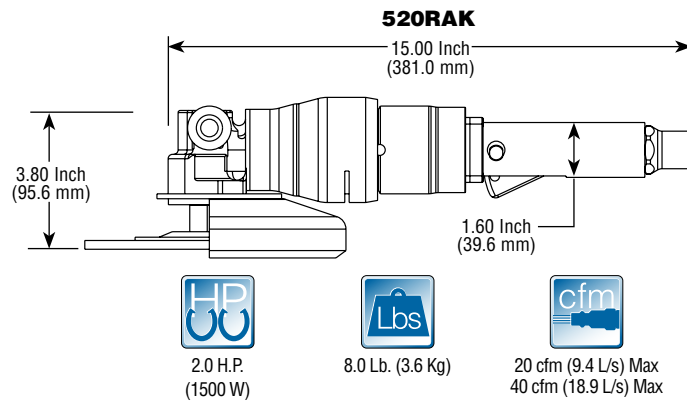
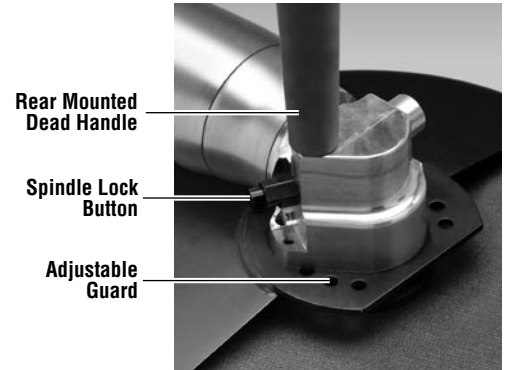

Example Model Number: **520RA 2 XLTKW ; 8000;727**

Model Number	Spindle Options	Lever Style	Operating Speed/Guard Size
520RA	Please choose one of the following options: 1 - 5/8-11 0.9 Inch 2 - 5/8-11 1.1 Inch	Please choose one of the following options: K - Safety Lever XL - Standard Lever XK - Safety Lever XB - Thumb Switch XLTK - Turned/Knurled Standard Lever XKTK - Turned/Knurled Safety Lever XBTk - Turned/Knurled Thumb Switch XLTKW - Turned/Knurled/Cushioned Standard Lever XKTKW - Turned/Knurled/Cushioned Safety Lever XBTkW - Turned/Knurled/Cushioned Thumb Switch	Please choose one of the following options: 6000;727 - 6000 R.P.M. with 7 Inch Wheel Guard 6000;927 - 6000 R.P.M. with 9 Inch Wheel Guard 8000;727 - 8000 R.P.M. with 7 Inch Wheel Guard 6000;1041 - 6000 R.P.M. with 10 Inch Wheel Guard*



Governor Controlled Tool Geared Tool

\*Available only with Type 2 Spindle

**WARNING: Follow all recommendations from component and abrasive manufacturers for speeds and proper usage.**